

Article number: 00 267 06 99

## Electronic wash basin tap XERIS E<sup>2</sup> HD-K large - high-pressure cold water/pre- mixed water

Contactless, sensor-controlled tap with innovative ToF technology. Insensitive against reflective materials such as mirrors, safety vests, etc. With integrated Bluetooth® interface. Configuration, evaluation and documentation via SCHELL app. Suitable for networking with the SCHELL SWS water management system. Mains operation (transformer plug).

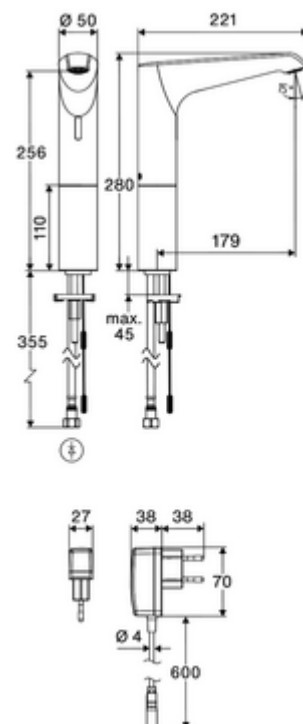

### Scope of delivery

- Time-of-flight sensor single-hole tap
  - Vandal-resistant all-metal housing
  - Time-of-flight sensor electronics (ToF) with automatic adjustment of the sensor range
  - Recessed aerator (theft-protected)
  - Connection cable, 360 mm, with 3-pin plug connector, protection class IP65
  - 6 V axial solenoid valve with pre-filter
  - Standpipe extension
- Transformer plug 9 VDC, 100-240 VAC, 50-60 Hz
- Flexible Clean-Fix S connection hose, G 3/8 IG x 500 mm, with integrated backflow preventer (EN 1717: EB-type) and pre-filter
- Fastening material for wash basin installation

### Technical data

- Setting options via SCHELL App
  - Quick configuration via preset operating modes (save electricity / save water / comfort)
  - Individual settings in expert mode (sensor range, sensor measuring interval, person detection, max. runtime, run-on time)
  - Stagnation flush (off / at intervals / smart demand-based flush taking usage into account / at fixed times [day(s), time])
  - Continuous flush for thermal disinfection, triggering via app (3 - 10 min)
  - Continuous flow, triggering via app (15 - 600 s)
  - Cleaning stop, triggering via app or proximity reflex (off / 60 - 360 s)
- S<sub>Durchfluss</sub>: max. 5 l/min pressure independent
- Flow pressure: 1.0 - 5.0 bar
- Max. Resting pressure: 8 bar
- Max. operating temperature: 70 °C (80 °C for thermal disinfection)
- Connection: G 3/8 IG
- Material: Housing Brass
- Surface: Chrome
- Certificates: PA-IX 10332/IO, DVGW applied
- Noise class: I
- Flow class: O

### Delivery data

- Weight: 2,00 kg/Piece
- Packing unit: 1

**Recommended associated articles**

Extension cable	Article no: 51 010 00 99 or
Extension cable	Article no: 51 023 00 99 or
Angle valve with regulating function COMFORT with filter	Article no: 05 430 06 99
Wash basin outlet valve OPEN	Article no: 02 002 06 99 or
Wash basin outlet valve PUSH OPEN	Article no: 02 000 06 99 or

**Hint**

- Previous Electronic washbasin tap XERIS E 01 209 06 99 expected to be available until II. quarter 2025.