

Article number: 00 265 06 99

Electronic wash basin tap XERIS E² HD-K large - high-pressure cold water/pre- mixed water

Contactless, sensor-controlled tap with innovative ToF technology. Insensitive against reflective materials such as mirrors, safety vests, etc. With integrated Bluetooth® interface. Configuration, evaluation and documentation via SCHELL app. Suitable for networking with the SCHELL SWS water management system. Excluding power supply. Intended for power supply via SCHELL water management system SWS or central power supply unit.

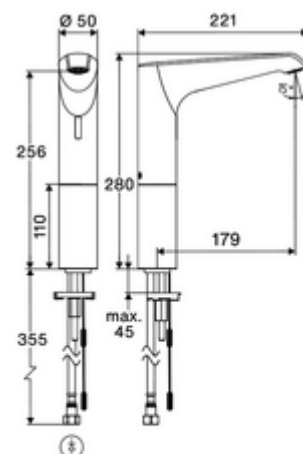

Scope of delivery

- Time-of-flight sensor single-hole tap
 - Vandal-resistant all-metal housing
 - Time-of-flight sensor electronics (ToF) with automatic adjustment of the sensor range
 - Recessed aerator (theft-protected)
 - Connection cable, 360 mm, with 3-pin plug connector, protection class IP65
 - 6 V axial solenoid valve with pre-filter
 - Standpipe extension
- Flexible Clean-Fix S connection hose, G 3/8 IG x 500 mm, with integrated backflow preventer (EN 1717: EB-type) and pre-filter
- Fastening material for wash basin installation

Technical data

- Setting options via SCHELL App
 - Quick configuration via preset operating modes (save electricity / save water / comfort)
 - Individual settings in expert mode (sensor range, sensor measuring interval, person detection, max. runtime, run-on time)
 - Stagnation flush (off / at intervals / smart demand-based flush taking usage into account / at fixed times [day(s), time])
 - Continuous flush for thermal disinfection, triggering via app (3 - 10 min)
 - Continuous flow, triggering via app (15 - 600 s)
 - Cleaning stop, triggering via app or proximity reflex (off / 60 - 360 s)
- S_{Durchfluss}: max. 5 l/min pressure independent
- Flow pressure: 1.0 - 5.0 bar
- Max. Resting pressure: 8 bar
- Max. operating temperature: 70 °C (80 °C for thermal disinfection)
- Connection: G 3/8 IG
- Material: Housing Brass
- Surface: Chrome
- Certificates: PA-IX 10332/IO, DVGW applied
- Noise class: I
- Flow class: O

Delivery data

- Weight: 2,10 kg/Piece
- Packing unit: 1

Necessary associated articles

SWS Server	Article no: 00 500 00 99
SWS Bus mains adapter	Article no: 00 505 00 99
SWS Bus extender cable BE-K	Article no: 00 501 00 99

Recommended associated articles

Angle valve with regulating function COMFORT with filter	Article no: 05 430 06 99
Wash basin outlet valve OPEN	Article no: 02 002 06 99 or
Wash basin outlet valve PUSH OPEN	Article no: 02 000 06 99 or
<u>Optional power supply via collective mains adapter</u>	
Concealed power supply unit 9 VDC, 100 - 240 VAC, 50 - 60 Hz	Article no: 01 315 00 99 or
Top-hat rail transformer 9 VDC, 100 - 240 VAC, 50 - 60 Hz	Article no: 01 582 00 99 or
Electrical junction box 9 VDC, 100 - 240 VAC, 50 - 60 Hz	Article no: 01 583 00 99 or

Hint

- Previous Electronic washbasin tap XERIS E 00 220 06 99 expected to be available until II. quarter 2025.