

Article number: 00 207 06 99

## Electronic wash basin tap MODUS E HD-K - high-pressure cold water/pre-mixed water

Infrared sensor-controlled. Excluding power supply. Suitable for networking with the SCHELL SWS water management system. Configurable via SCHELL Single Control SSC. Intended for power supply via SCHELL water management system SWS or central power supply unit.

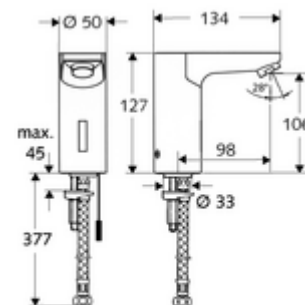

### Scope of delivery

- Infrared sensor single-hole tap
  - Vandal-resistant all-metal housing
  - 6 V solenoid valve with pre-filter
  - Aerator
  - Infrared sensor electronics, programmable
  - Connection cable, 250 mm, with 3-pin plug connector, protection class IP65
- Flexible Clean-Fix S connection hose, G 3/8 IG x 380 mm, with pre-filter
- Fastening material for wash basin installation

### Technical data

- Setting options via SWS SSC
  - Sensor range (short/medium/long)
  - Programming via short range reflex (off/on)
  - Max. flow time (1-360 s)
  - Follow-up time (0.6-60 s)
  - Stagnation flush (off/5-600 s, every 1-240 h after last flush/every 1-240 h)
  - Continuous flush for thermal disinfection, with anti-scalding protection (off/15-600 s)
  - Duration of flow (off/15-600 s)
  - Energy saving mode (off/1-254 h after last flush)
  - Cleaning stop (off/60-360 s)
- Setting options via short range reflex
  - Sensor range (short/medium/long)
  - Stagnation flush (off/30 s, every 24 h after last flush/every 24 h)
  - Continuous flush for thermal disinfection, with anti-scalding protection (off/300 s/120 s)
  - Cleaning stop (off/60 s)
- S\_Durchfluss: max. 5 l/min pressure independent
- Flow: 1.0 - 5.0 l/min
- Max. Resting pressure: 8 bar
- Max. operating temperature: 70 °C (80 °C for thermal disinfection)
- Connection: G 3/8 IG
- Material: Housing Brass, conform to German drinking water regulations
- Surface: Chrome
- Certificates: P-IX 19116/IZ
- Noise class: I
- Flow class: Z

### Delivery data

- Weight: 1,82 kg/Piece
- Packing unit: 1

---

### Necessary associated articles

SWS Server	Article no: 00 500 00 99
SWS Bus mains adapter	Article no: 00 505 00 99
SWS Bus extender cable BE-K	Article no: 00 501 00 99

### Recommended associated articles

Angle valve with regulating function COMFORT with filter	Article no: 05 430 06 99
Wash basin outlet valve OPEN	Article no: 02 002 06 99 or
Wash basin outlet valve PUSH OPEN	Article no: 02 000 06 99 or

#### Optional power supply via collective mains adapter

Concealed power supply unit 9 VDC, 100 - 240 VAC, 50 - 60 Hz	Article no: 01 315 00 99 or
Top-hat rail transformer 9 VDC, 100 - 240 VAC, 50 - 60 Hz	Article no: 01 582 00 99 or
Electrical junction box 9 VDC, 100 - 240 VAC, 50 - 60 Hz	Article no: 01 583 00 99 or

### Hint

- Discontinued article, as long as stocks last
- Successor model: CELIS E<sup>2</sup>, art. no. 00 273 06 99